



ARTICULO: 2220

Válvula de compuerta extremos roscados. Threaded ends Gate valve.

Características

1. Válvula de compuerta.
2. Construcción en acero inoxidable CF8M.
3. Disco compacto en CF8M.
4. Vástago no ascendente.
5. Extremos roscados según DIN 2999 std.
6. Estopada de eje en PTFE.
7. Presión máxima de trabajo 16 Kg. / cm².
8. Temperatura Máxima de trabajo: 180 °C.

Features

1. Gate valve.
2. Made by Stainless Steel CF8M.
3. Compact disc made by CF8M.
4. Non-rising stem
5. Threaded ends according DIN 2999 std.
6. Stem Packing PTFE.
7. Max. Working pressure 16 Kg. / cm²
8. Max. Working temperature 180 °C.

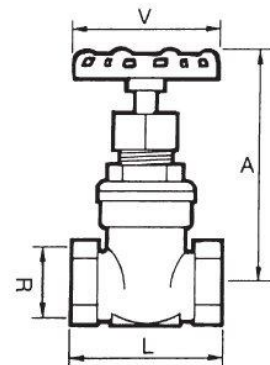
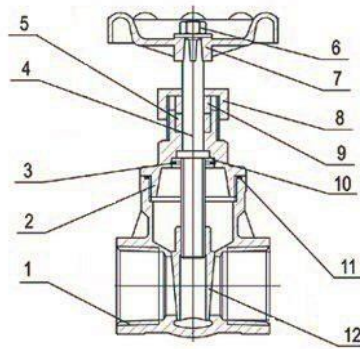

Nº	Denominación/Name	Material	Acabado Superficial/Surface Treatment
1	Cuerpo / Body	Acero Inoxidable CF8M / S.S. CF8M	Granallado / Shot blasting
2	Tapa / Bonnet	Acero Inoxidable CF8M / S.S. CF8M	Granallado / Shot blasting
3	Arandela / Washer	Acero Inoxidable 304 / S.S. 304	-----
4	Eje / Stem	Acero Inoxidable 316 / S.S. 316	-----
5	Estopada / Stem packing	PTFE	-----
6	Tuerca / Nut	Acero Inoxidable 304 / S.S. 304	-----
7	Volante / Handwheel	Aluminio / Alluminium	Pintado / Painted
8	Tuerca prensaestopas / Packing nut	Acero Inoxidable 316 / S.S. 316	-----
9	Prensa estopa / Stem Packing	Acero Inoxidable 316 / S.S. 316	-----





Nº	Denominación/Name	Material	Acabado Superficial/Surface Treatment
10	Traba Tuerca / Lock Nut	Acero Inoxidable 316 / S.S. 316	-----
11	Junta Cuerpo / Body Gasket	Teflón / PTFE	-----
12	Compuerta / Wedge	Acero Inoxidable CF8M / S.S. CF8M	Granallado / Shot blasting

DIMENSIONES GENERALES / GENERAL DIMENSIONS

Ref	Medida/Size	PN	Dimensiones/Dimensions (mm)				Peso/Weight (Kg)
			R	A	L	V	
2220 04	1/2"	16	1/2"	100	54	70	0.414
2220 05	3/4"	16	3/4"	110	58	70	0.578
2220 06	1"	16	1"	115	65	70	0.740
2220 07	1 1/4"	16	1 1/4"	130	75	80	0.995
2220 08	1 1/2"	16	1 1/2"	150	78	100	1.459
2220 09	2"	16	2"	167	93	100	1.985

DIAGRAMA DE PERDIDAS DE CARGA / HEAD LOSSES DIAGRAM

(H₂O – 20 °C Flujo Horizontal / Horizontal flow).

